



# BoxMaster™

Reliability >>>>> Productivity >>>>> Robustness >>>>>

## DATASHEET

SAFE • STRONG • SMART

### Fully-Automatic Case-Former

BoxMaster™ is an automatic case erector designed to form and seal with adhesive tape or hot melt the bottom of boxes. The machine runs at a variable speed of up to 1.100 boxes/hour according to box dimensions. Machine adjustments are fast, simple and repeatable.

#### KEY FEATURES

- ✓ **Safety First** – BoxMaster™ incorporates several safety features as standard
- ✓ **Production capacity** – standard box storage capacity of 150 boxes, 300 boxes as option
- ✓ **Production throughput** – output up to 1.100 boxes/hour
- ✓ **Production flexibility** – manages boxes from 150 x 125 x 80 mm to 620 x 500 x 500 mm (depending on the version)
- ✓ **Customized programs** – customizable programs with advanced settings.
- ✓ **Easy-to-use** – controlled by PLC and HMI, mechanical setting with counter
- ✓ **Modular system** – meeting your individual needs
- ✓ **Easy installation** – delivered full assembled, with wheels



#### DIMENSIONS

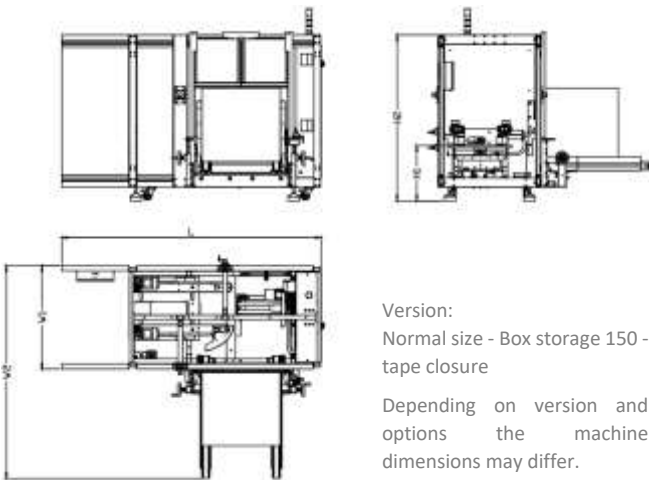

Version:  
Normal size - Box storage 150 - tape closure  
Depending on version and options the machine dimensions may differ.

Machine Dimensions (mm)		
	Standard	Big
workbench height H1 (std.)	600 - 700	
max. height H1	2.085 / 2.285	
max. width W2 (box storage 150)	2.420	2.770
max. width W2 (box storage 300)	3.020	3.370
max. length L (tape closure)	2.850	2.980
max. length L (hot-melt closure)	3.820	3.940

#### TOUCH SCREEN DISPLAY

The newly structured operator software and the layout of the operator interface allow the user to quickly and flexibly adjust the machine settings to match the individual requirements of each specific application.



The setting and operation are designed to be highly intuitive.

- 7" touch screen control panel
- Full Siemens architecture
- Automatic, manual and step by step working mode
- Customizable programs
- Boxes counter
- Help and diagnostics
- Production throughput visualization



## DATASHEET

### SOFTWARE

**As standard:** User friendly Software



Program Page

- Customizable programs with more than 25 parameters for a perfect setting of the operations according to customer needs.

- Autonomous diagnostic with the possibility to control all single machine operations, in order to detect potential errors and operation faults.



Manual Operation Page

### COUNTERS ON HANDLES

**As standard:** Setting-Counters on all relevant handles.

The Counters allow to easily adjust the relevant mechanic settings in a fast and repeatable way.

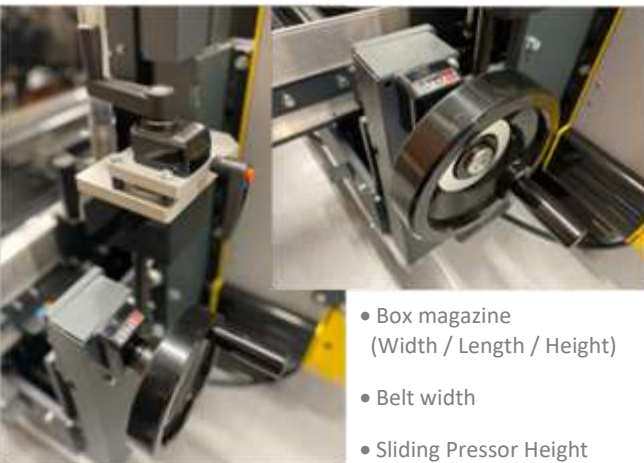

- Box magazine (Width / Length / Height)
- Belt width
- Sliding Pressor Height

### END- & BREAK-TAPE DEVICE

**As standard:** Detection of torn tape and end of the tape reel.

BoxMaster automatically detects if the applied tape is broken during the taping process and interrupts the taping process as result.

Further BoxMaster can signalize when the uses tape reel is ending.

### END CYCLE & FULL-LINE DETECTION

**As standard:** 2 Photocells to detect:

#### a) End Cycle

On the exit of the motorization, to check the exit of the box and stop the machine, if it is not free.

#### b) Full Line

Can be placed separately at the outfeed conveyor line, to stop the machine after the boxes have piled up. Standard length 5m.

### BOX-PRESSOR

**As standard:** Newly designed slidable Box-Pressor

Easy and fast adjustment to the needed box dimension and possibility to quick change of the Taping Unit, thanks to the newly designed slidable integration. To perfectly process the formed box, through the bottom taping section of the BoxMaster. Avoiding any unintentional upwarding of the box.



### SIGNAL EXCHANGE

**As standard:** Exchange Signals to connect with adjacent conveying systems.

Output:

- Machine working
- Emergency
- Alarm
- Broken tape (only for tape box closure)
- Box ready

Input:

- Full line



### SQUARE BOX FORMING

**As standard:** Possibility to form squared boxes (Length x Width).



BoxMaster can process squared boxes. Please consider that for squared boxes the design of flap cutting is important. *Contact us for more information.*

### VACUUM SYSTEM

**As standard:** Venturi-System

The system generates a vacuum at the cardboard box suction cups by accelerating the compressed air flow (Venturi effect) without additional drive elements.

Less electrical power consumption and less wearing parts. But increased demand on compressed air.

**OPTIONAL:** Pump system

Pump-System with lower demand on compressed air. But increased demand on electrical power.

*More Technical Details on bottom of page 3.*



# BoxMaster™



## DATASHEET

### FRAME

Open frame structure, with stiff and strong chassis. This allows a full visibility and access to the mechanical part of the machine for easy maintenance. Wheels on the structure allow an easy positioning of the machine.



### BOX STORAGE

Lean and strong design to allow easy box loading. Counter on the adjustment for fast and precise box dimension setup.

The standard box storage can store up to 150 boxes, the optional extended version can store up to 300 boxes.



### FENCES

Clean and modern design. Large doors to enable full access to the inside of the machine.



### CARRIAGE AXES

Strong design with double 40 mm diameter shaft and ball bushing to allow a precise, smooth and fast movement.



### ELECTRICAL & PNEUMATICAL SUPPLY

Vacuum System	Version	Power Supply	Power kW	Amps	SCCR	IP class	Air Supply	Air consumption	
Venturi (std.)	AC motors	380/415 V - 50 Hz - 3 PH+N	1,2	4,8	3 kA	54	6 bar	3 NL / Cycle	
	Brushless motors		2,4	10,2					
Pump (optional)	AC motors		1,9	7,6				13	1,5 NL / Cycle
	Brushless motors		3,2						

## DATASHEET

### LAYOUT

The position of the box storage and of the operator can fit your layout needs, considering the individual box orientation.

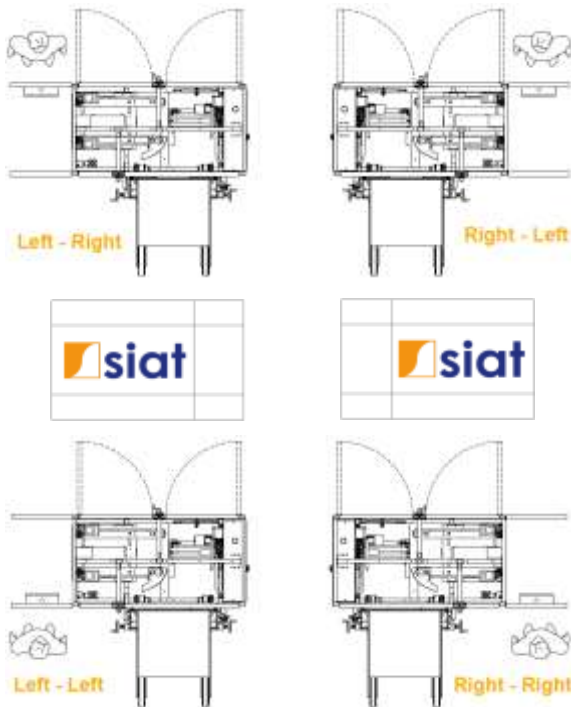

### HOT-MELT CLOSURE

Closure by hot melt. ROBATECH® Hot Melt glue dispenser positioned on an external carriage with casters (other brands available upon request).

Power Supply	
380/400V – 50Hz - 3ph	
440V – 60Hz - 3ph	
Amps	4,5
Power kW	2,24
Phase	3Ph + N + PE



### BOX REQUIREMENTS

Quality result of the taped box depends on the general box quality and dimensional accuracy, as well as the quality of tape used.

Box Types: FEFCO 0201 – RSC  
 Flute Type: B, C, E  
 Wall Type: Single and Double Wall

### ENVIRONMENTAL CONDITIONS

Maximum operating height (asi)	M	1000
Humidity range	%	20 - 80
Operating temperature	°C	5 - 40
Environmental brightness	LUX	N.A.
Maximum level of noise	dB	Depending on tape quality



SAFE • STRONG • SMART

### BOX DIMENSIONS

Two machine sizes are available to manage different box dimensions.

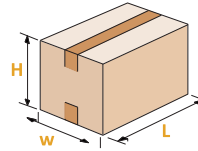

Box Dimensions <sup>1</sup>		Standard	Big
L (mm)	Min.	150	300
	Max.	500	620
W (mm)	Min.	125 / 150 <sup>2</sup>	
	Max.	350	500
H (mm)	Min.	80	150 <sup>3</sup>
	Max.	450	500

- <sup>1</sup> General Guide: L + W = > 300 mm for Std. and > 350mm for Big
- <sup>2</sup> Depending on the Taping Unit width: K11 (50 mm) or K12 (75 mm)
- <sup>3</sup> Optional as Low-Box-Version: H = 80 mm

### PRODUCTIVITY

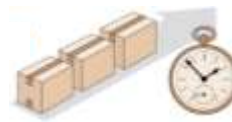

Max. production capacity:  
**Up to 18\* BPM**

\* Based on the smallest processable box and as Brushless Motor Version for adhesive tape.

The standard version is equipped with AC motors, constant speed, to drive the two carriages, picking from box storage and pushing in the closure station. The high-speed version is equipped with brushless motors.

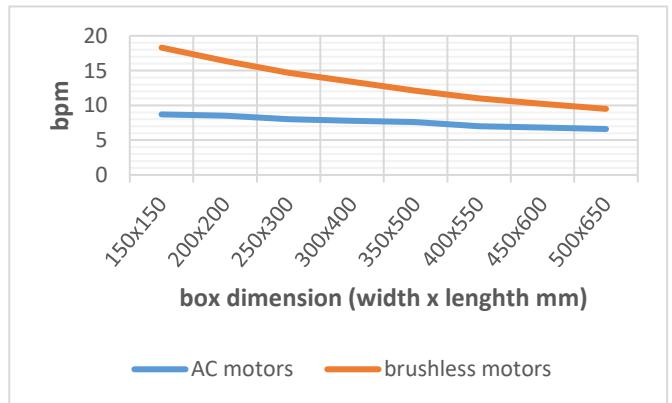

### TAPE CLOSURE

Closure by PST tape applied with SIAT taping unit available on 50 mm (2") or 75 mm (3").

Base Material	PVC / OPP / PET / Paper*
Adhesive Type	Solvent / Hot Melt / Acrylic
Special Tape	Filament-Tape** / Safety-Seal-Tape***

\*with limitations \*\*special tape cutting blade required \*\*\*need of a test might be necessary

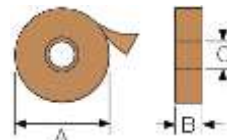

K11 / K12	
A	Max. 410 mm
B	50 / 75 mm
C	76 mm

### OPTIONS

- OptiRun System
- Different Working Height
- Pump (instead of Venturi)
- Increased Box Storage capacity

### MORE DETAILS

Videos and further information can be found on our website or SIAT Youtube channel.



SIAT.com